



-shown with optional basic bezel

PHD50 Parker Hannifin Display 5.0"

Catalog MSG33-5022/US



ENGINEERING YOUR SUCCESS.

Application

The PHD50 is one of a family of general purpose displays for vehicle instrumentation. The display can be supplied with an optional standard bezel. The end user can customize the PHD50 with their own custom bezel and by creating custom application software. By incorporating the new display, a wide range of industrial vehicles can be operated more efficiently for greater productivity.

Properties

Features

The PHD50 display has a rugged mechanical design with no moving parts, and is sealed against dust and water ingress. The display is also designed to withstand extended temperatures, high vibration and EMC/EMI conditions found on today's mobile equipment.

The versatile PHD50 display has a pleasing, aesthetic design that blends into modern vehicle cabs. A capacitive touchscreen interface offers interactive, intuitive HMI. If desired, the general purpose IO may be configured for a 3x4 matrix keypad or buttons.

The PHD50 supports J1939 and CANopen CAN communication interfaces. The PHD50 has 10 configurable inputs. 8 of the inputs have flexible usage as digital inputs or 0-5V analog inputs. There are 2 frequency inputs. For outputs, the PHD50 has 2 low-side outputs that are rated for a maximum current of 500 mA; 1 output has pulse width modulation capabilities. Low-side outputs have analog feedback which provides open circuit, short to battery, and short to ground detection. Additionally, all 10 PHD50 inputs may be re-purposed as low voltage, high-side outputs.

Mounting is easy, with steel clips or screw tabs, for a flush mount in dash panels. The PHD50 may be mounted in landscape or portrait orientation for easy integration into your machine's HMI design.

Reliability

The PHD50 is ideal for various industrial and off-road vehicle applications, with a 5.0", TN twisted-nematic color LCD, 800 x 480 pixel screen with dimmable backlight. The enclosure is designed to be used in outdoor environments, and has been tested to a suitable mix of standards based on the J1455, ISO, and EP455 environmental specifications. The 2 connectors are a rugged, environmentally sealed, Molex MX150 type.

General

Weight	312 g
Temperature range	
- Operating, ambient	-40 ¹ to +70°C
- Storage, ambient	-40 to +85°C
Protection	IP65 (back), IP69K (front)
Voltage supply	9 - 32 Vdc
Current (standby)	<10 mA (12Vdc)
Performance	
Processor	Vybird VF5xxR (Cortex-A5 core)
Memory	32 MB Flash 256 MB DDR3
Operating system	Linux
Software tools	Crank Storyboard (graphics)

Communication

CAN (J1939/CANopen)	1 (Wake on CAN)
USB	1 Host or Device (default)

Outputs

Power out (sensor supply)	3
- Type	high-side switch
- Max load	500 mA
- Voltage	2x 5 Vdc (1 intended for USB) 1x 12 Vdc (derated < 13.3 V)
Digital out, low-side	2 (1 may be PWM)
- Max load	500 mA
- Max PWM frequency	200 Hz
Digital out, high-side	up to 10 ²
- Max voltage	4.3 Vdc
- Max load	5 mA

Inputs

Configurable inputs	10 ²
- digital, active-high	up to 8 ³
signal high	4 - 32 Vdc
signal low	0 - 1 Vdc
- analog, 0-5 Vdc	up to 8 ³
- encoder/pulse	up to 2
Video inputs	
- NTSC/PAL	1

Connector

Type	Molex MX150, key A & B
------	------------------------

- 1 Some contrast degradation and slower response will be seen on the LCD at temperatures below -20°C.
- 2 The inputs and high-side outputs share the same physical pins. By configuring the pins with software, the user defines the pins as digital inputs, analog inputs or high-side outputs.
- 3 Selectable inputs are able to be defined as 'wake-up' inputs.

Ordering part numbers

PHD50	1041003ECD
Basic bezel	1041503ECD
Connector kit	1041050ECD

Environmental protection

EMI

- J1455 Section 4.13.1, Over-voltage
- J1455 Section 5.10.3, Reverse polarity
- J1455 Section 5.10.4, Short circuit
- ISO7637 Section 5.6.x, EP455 Section 5.11.x, Transients
- ISO14982, EMC emissions
- ISO14982, EMC susceptibility

Mechanical environment

- BS EN7691 Section 6.6.1, Random vibration
- EP455 Section 4.11.3.1, Drop test

ESD

- EN61000-4-2, Surface and connectors

Climate environment

- IEC 60529 Section 14.2.5, Water IP65
- IEC 60068-2-5 UV Exposure
- IEC 68-2-2 Section 4, High temperature
- IEC 68-2-1 Section 2, Low temperature
- EP455 Section 5.1.1, Temperature cycle
- J1455 Section 4.1.3.2, Temperature shock
- EP455 Section 5.13.2, Humidity soak
- EP455 Section 4.3.2, Humidity cycle
- MIL_STD 202G M101E-A, Salt spray

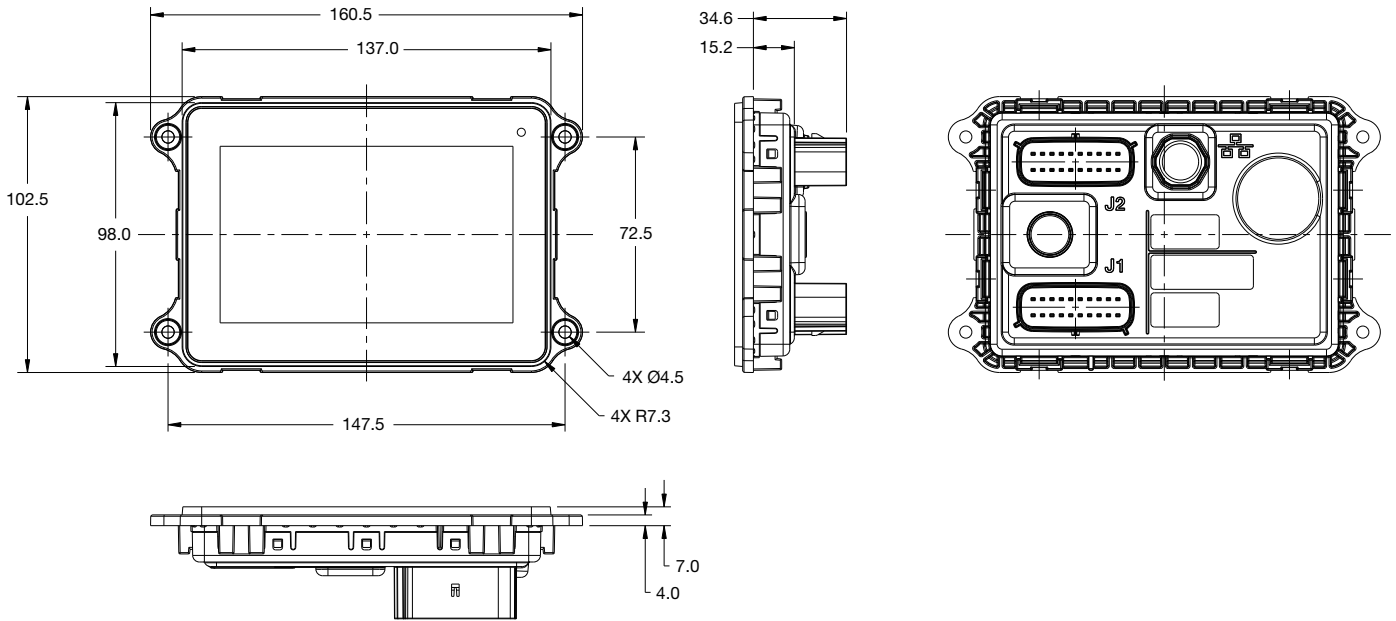

units=mm



WARNING - USER RESPONSIBILITY

FAILURE OR IMPROPER SELECTION OR IMPROPER USE OF THE PRODUCTS DESCRIBED HEREIN OR RELATED ITEMS CAN CAUSE DEATH, PERSONAL INJURY AND PROPERTY DAMAGE.

- This document and other information from Parker-Hannifin Corporation, its subsidiaries and authorized distributors provide product or system options for further investigation by users having technical expertise.
- The user, through its own analysis and testing, is solely responsible for making the final selection of the system and components and assuring that all performance, endurance, maintenance, safety and warning requirements of the application are met. The user must analyze all aspects of the application, follow applicable industry standards, and follow the information concerning the product in the current product catalog and in any other materials provided from Parker or its subsidiaries or authorized distributors.
- To the extent that Parker or its subsidiaries or authorized distributors provide component or system options based upon data or specifications provided by the user, the user is responsible for determining that such data and specifications are suitable and sufficient for all applications and reasonably foreseeable uses of the components or systems.

OFFER OF SALE

The items described in this document are hereby offered for sale by Parker-Hannifin Corporation, its subsidiaries or its authorized distributors. This offer and its acceptance are governed by the provisions stated in the detailed "Offer of Sale" elsewhere in this document or available at www.parker.com.

California Proposition 65  WARNING:

This product can expose you to chemicals including 4,4'-(PROPANE-2,2-DIYL)DIPHENOL, BPA, P,P'-ISOPROPYLIDENE BISPHENOL, which is known to the State of California to cause birth defects or other reproductive harm.

For more information go to www.P65Warnings.ca.gov

Parker Hydraulics International Sales Offices

North America

Motion Systems Group Headquarters

6035 Parkland Boulevard
Cleveland, OH 44124-4141 USA
Tel: 216-896-3000
Fax: 216-896-4031

Parker Canada Division

160 Chisholm Drive Milton
Ontario Canada L9T 3G9
Tel: 905-693-3000
Fax: 905-876-1958

Parker Hannifin de México

Industrial Hydraulic Sales
Eje Uno Norte No.100
Parque Industrial Toluca 2000
Toluca, Edo, de Mexico CP 50100
Tel: 52 722 275 4200
Fax: 52 722 279 9308

Parker Hannifin de México

Mobile Hydraulic Sales
Via de FFCC a Matamorao 730
Apodaca, NL, de Mexico CP 66600
Tel: 52 81 8156 6000
Fax: 52 81 8156 6068

Europe

Motion Systems Group Headquarters

La Tuilière 6
1163 Etoy - Switzerland
Tel: 41 21 821 8500
Fax: 41 21 821 8580

South Africa

Parker Hannifin Africa Pty Ltd

P.O. Box 1153
ZA-Kempton Park 1620,
Republic of South Africa
Tel: 27 11 961 0700
Fax: 27 11 392 7213

Mobile Sales

Mobile Sales Organization and Global Sales

850 Arthur Avenue
Elk Grove Village, IL 60007 USA
Tel: 847-258-6200
Fax: 847-258-6299

Industrial Sales

Central Region

1042 Maple Avenue
Unit 331
Lisle, IL 60532 USA
Tel: 630-964-0796

Great Lakes Region

6035 Parkland Boulevard
Cleveland, OH 44124-4141 USA
Tel: 216-896-2740
Fax: 866-498-7507

Gulf Region

20002 Standing Cypress Drive
Spring, TX 77379 USA
Tel: 817-473-4431
Fax: 888-227-9454

Southwest Region

700 S. 4th Avenue
Mansfield, TX 76063 USA
Tel: 817-473-9341
Fax: 817-473-2680

Mid Atlantic and Southeast Regions

1225 Old Alpharetta Road
Suite 290
Alpharetta, GA 30005 USA
Tel: 770-619-9767
Fax: 770-619-9806

Midwest Region

8145 Lewis Road
Minneapolis, MN 55427 USA
Tel: 763-513-3535
Fax: 763-544-3418

Northeast Region

P.O. Box 396
Pine Brook, NJ 07058 USA
Tel: 973-227-2565
Fax: 973-227-2467

Northwest Region

6458 North Basin Avenue
Portland, OR 97217 USA
Tel: 503-283-1020
Fax: 866-611-7308

Pacific Region

8460 Kass Drive
Buena Park, CA 90621
Tel: 714-228-2510
Fax: 714-228-2511

Asia Pacific

Parker Hannifin Shanghai Ltd

280 Yunqiao Road,
Jin Qiao Export Processing Zone
Shanghai 201206, China
Tel: 86 21 2899 5000
Fax: 86 21 6445 9917

Parker Hannifin Hong Kong Ltd

8/F, Kin Yip Plaza
9 Cheung Yee Street
Cheung Sha Wan, Hong Kong
Tel: 852 2428 8008
Fax: 852 2425 6896

Parker Hannifin Korea Ltd

9F KAMCO Yangjae Tower
949-3 Dogok1-dong, Gangnam-gu
Seoul, 135-860, Korea
Tel: 82 2 559 0400
Fax: 82 2 556 8187

Parker Hannifin India Pvt Ltd

Plot No. EL-26, MIDC
TTC Industrial Area
Mahape, Navi Mumbai, 400 709 India
Tel: 91 22 6513 7081
Fax: 91 22 2768 6841

Parker Hannifin Australia

Parker Hannifin Pty Ltd.
9 Carrington Road
Castle Hill, NSW 2154, Australia
Tel: 612 9634 7777
Fax: 612 9842 5111

Latin America

Parker Hannifin Ind. e Com. Ltda Hydraulics Division

Av. FredericoRitter, 1100
94930-000 Cachoeirinha RS, Brazil
Tel: 55 51 3470 6090
Fax: 55 51 3470 9281

Parker Hannifin Argentina S.A.I.C.

Stephenson 2711
1667-Tortuguitas-Malvinas Argentinas
Pcia. de Buenos Aires, Argentina
Tel: 54 3327 44 4129
Fax: 54 3327 44 4199

Pan American Division

7400 NW 19th Street, Suite A
Miami, FL 33126 USA
Tel: 305-470-8800
Fax: 305-470-8808

